



Founded by Hugh G. Conway, C.B.E. in 1987

For the advancement of education through the study of works of Ettore Bugatti

Contacts: Richard Day Curator
Julie Bridcutt Secretary
David Morys Photographer

Office Hours: Monday – Friday 10.00 a.m. – 4.00 p.m.

Address: The Bugatti Trust, Prescott Hill, Gotherington, Cheltenham, Gloucestershire GL52 9RD, UK
Tel. +44(0)1242 677201 Fax +44(0)1242 674191
E-mail: info@bugatti-trust.co.uk www.bugatti-trust.co.uk

Trustees

H. R. G. Conway (Chairman), Angela Hucke, B. B. D. Kain, J. G. Marks,
A. B. Price, Lord Raglan, G. S. St. John, A. C. Trevelyan, Sir John Venables-Llewelyn

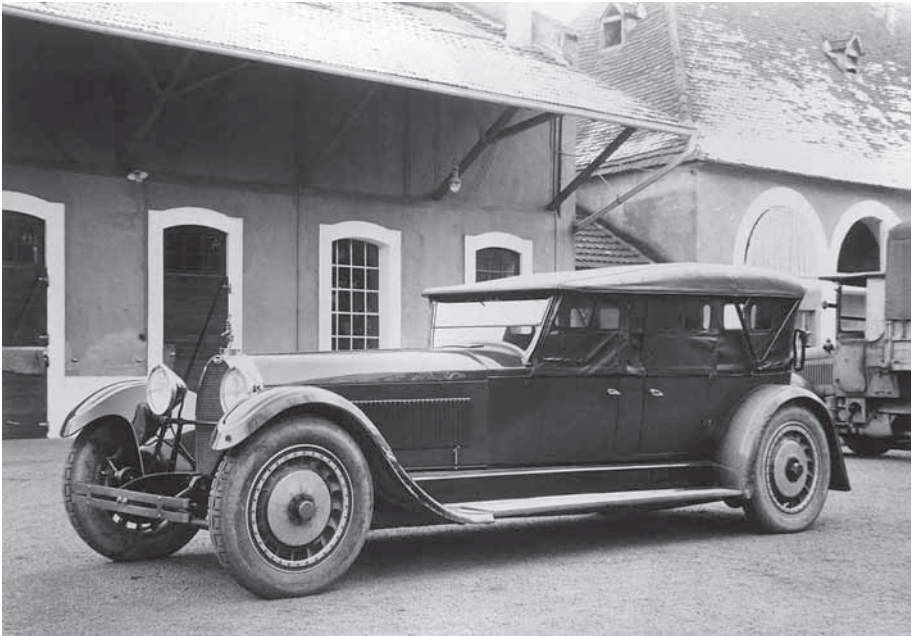

The prototype Royale in a familiar Molsheim location. At this early stage, in 1927, the car had its first Packard coachwork, small brakes and Rapson Tyres.

Chairman's Report

As we come to the end of the centenary year for the Bugatti factory in Molsheim it is worth acknowledging that most industrial companies fail to survive that long. Literally hundreds of automotive manufacturing organisations came and went in the early years. The company as we know it went through difficult times following Ettore's death and only survives as a result of its purchase by Hispano-Suiza in 1963.

The current owner of the factory Messier-Bugatti is today a major manufacturer of aircraft landing gear. It clearly appreciates the benefits of the Bugatti heritage. It has put significant investment into restoring many of the original buildings, including where the first models were assembled. Most buildings have been put to good use, including the Bugatti family residence which is now a training and conference centre.

The Chateau St Jean, coach houses and most recently orangery, which were all in a derelict state by the time they were acquired by VW have been restored and are used in the promotion of its new Veyron car.

The town of Molsheim too has realised the benefits to its tourism industry in promoting Bugatti. One can even follow a heritage trail! Credit for much of this is undoubtedly due to Paul Kestler, founder of the Bugatti Enthusiasts Alsace in 1979 and creator of the Bugatti Foundation. More recently the town's Musée de la Chartreuse has had a section permanently put aside for the display of Bugatti artefacts.

The Formula Student team competition, which the Trust supports, has an international reputation and has proved extremely successful in providing encouragement to young university engineering students. It was most gratifying to see that a number of teams were able to get together at Prescott in September and demonstrate their cars despite having now graduated. For that one must thank Trish Davis who persuaded so many to attend and whose initiative it was.

No one can possibly predict what will befall us in the next five years, let alone one hundred but we in the Bugatti Trust will continue to promote innovative engineering design as epitomised by the works of Ettore and his son Jean.

Bugatti's Patents – Supercharging

Richard Day

Ettore Bugatti's French Patents show us that he was looking into the question of supercharging his Grand Prix cars even before the introduction of the Type 35 at Lyon in August 1924.

Supercharging had been developed during the First World War, by Fiat and Mercedes, for their aero-engines and these two companies were early users of blown engines for their racing cars – Mercedes first, in the April 1922 Targa Florio and Fiat with the 1½ litre 803 that won the Voiturette race at Brescia in June 1923 and then the two litre Grand Prix cars in the French Grand Prix at Tours in July of that year.

Both of these manufacturers' superchargers pressurized the air supply into their carburettors rather than fitting them between the carburettor and the engine. Mercedes used a Roots blower but, at Tours the Fiats had Wittig type rotary-vane blowers which were unsuccessful in that event. The Tours road circuit, 35 laps of 14.2 miles, was rough and dusty and the delicate vane mechanism, probably with inadequate lubrication, did not last the race distance, allowing the unsupercharged Sunbeams to finish 1st and 2nd with the Bugatti Type 32 of Friderich 3rd. For their next race, at Monza, Fiat had replaced the Wittig vanes with Roots rotors and they won.

Bugatti first introduced supercharging for his Grand Prix cars with the

experimental, modified Type 36 on the 30 May 1926 at the Grand Prix d'Alsace. The factory drawings for the Edmond Moglia designed Roots blower date from August 1925 and are all designated 'Type 39'. By this stage the supercharger was fitted between the carburettor and the engine with the carburettor working at ambient pressure.

Bugatti's Patents show us that he was initially thinking along Mercedes lines (not for the first time) but with a rotary-vane unit which could be engaged by the driver when extra power was required and arranged to blow air into the carburettor.

Bugatti's French patent number 576.182 for "*Compresseur ou pompe à palettes*" was sought on 22 January 1924 and

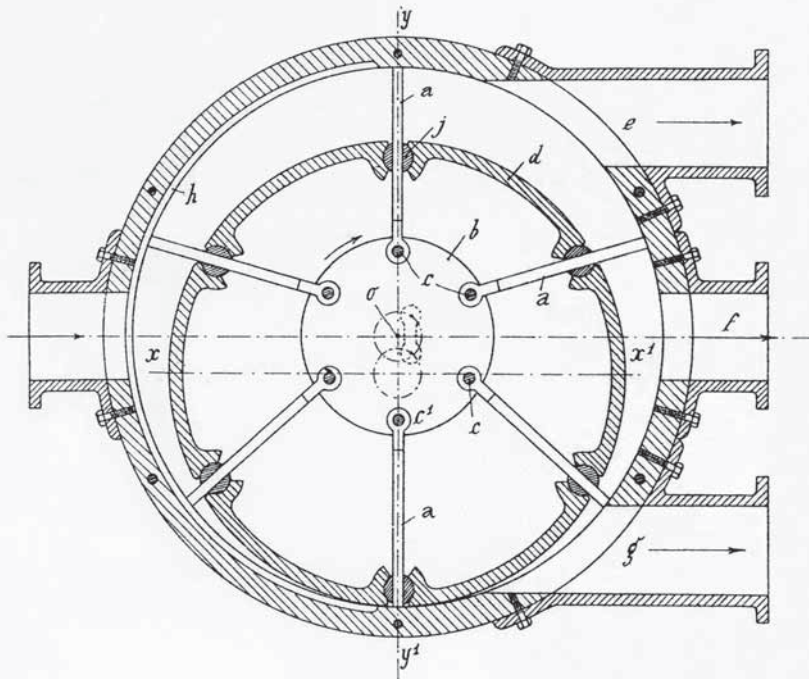

Bugatti French patent number 576.182

it shows a neat articulated multi vane arrangement with triple outlets which Bugatti claimed would produce a smooth flow.

The Bugatti French Patent number 586.717, sought on 30 September 1924, was for a special dual operating carburettor designed to work at ambient pressure for normal running but able to take a forced air supply when the driver engaged the blower. This Patent was titled '*Carburateur permettant la surcompression*' and is interesting because it explains Ettore's concerns about two potential difficulties. The first is the need to balance the float chamber pressure with the increased air supply and all the attendant pipe work and shrouding if the carburettor is on the pressure side of the blower and the

second is the difficulty of providing adequate lubrication of the rotary-vane mechanism if it is fitted down-stream of the carburettor because the fuel mixture would wash out the oil.

'The invention overcomes these problems'.

The carburettor is essentially composed of two parts, one being a normally aspirated carburettor functioning at low speeds, the other for high speeds with a supply of compressed air from a blower, but only when required. Then the first continues to work, with its venturi, in combination with the second.

At low speeds the central jet 'C' supplies petrol into the venturi of the choke tube B.

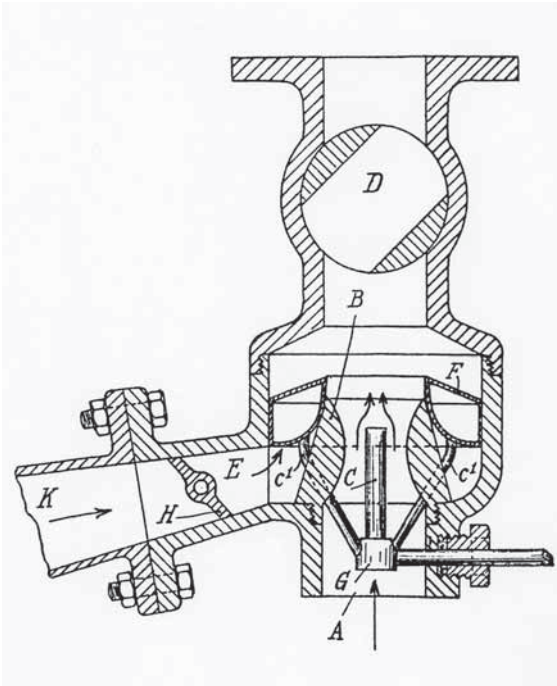

For higher speeds an engine driven blower is engaged to supply air at a certain pressure via the tube 'K' to a space around the choke. There is a very light weight blocking ring 'F' which is lifted by this air pressure uncovering a number of supplementary jets and thus providing a forced supply of petrol/air melange from an annular venturi. This would seem to result in a very neat arrangement.

From at least the time of the French Grand Prix at Tours in 1923 – when the supercharged Fiats showed their speed potential before they failed – Bugatti must have been impressed. These patents give us an insight into the development of his reply.

Bugatti French patent number 586.717

Bugatti's Paris Locations – Rue du Débarcadère

Richard Day

As we hoped, some Trust members have responded to our piece in the last Newsletter about the Bugatti Showrooms in Paris. We are most grateful to Dick Ploeg for his conclusion that the picture of the Type 55 faux cabriolet shown on page 12 was taken in front of 15 Rue du Débarcadère and not Avenue Montaigne as we had stated. Dick's letter is most interesting:

I read with interest your article concerning the Bugatti showrooms in Paris in Newsletter #32. In case you weren't aware, the Newsletter is read with interest and always eagerly awaited!

The illustration on page 12, showing the T55 Coupe is not, I think, of the Avenue Montaigne, but was taken in front of Bugatti's Rue du Débarcadère number 15 premises.

The often repeated story is that Ettore rented the building from the Zenith Carbuirettor company. But the early 1930s pictures showing the early T55 roadster and coupe, and the picture with Frederic Loiseau show "Automobiles Bugatti" panels on the facade and only the 1940 picture with Lucien Wurmser shows Zenith panels and a sign that the building is for sale.

Shortly before he left us, I had an exchange of letters with Les Matthews on the subject of the Rue du Débarcadère address. Unfortunately we never completely resolved the matter, but Les accepted that the information he had published about the Rue du Débarcadère address needed to be revised in the light of this photographic evidence.

My idea is that the Rue du Débarcadère address was never used commercially, but was reserved for special projects.

Why in particular it was chosen as a backdrop for the T55 model is open to debate, but from 1936 on it was used as the design office and workshop for the Bugatti De Monge airplane. Conceivably the Zenith panels may as from then have been put on the facade to give the impression that Zenith had rented the building and thereby provide cover for the secret aircraft project. Of course this is pure conjecture on my part.

What we can glean from these photographs is that Bugatti used 15 Rue du Débarcadère from the time of Frederic Loiseau's Sahara raid until at least 1940.

What also remains is that, to the best of my knowledge, there have never been published any photographs yet showing the exterior of the 46 Avenue Montaigne showrooms. This seems weird as common sense suggests that such photos must have existed.

I would be much interested in any new information with respect to the various Bugatti addresses. My own research so far has only yielded demolished sites (Av Montaigne, Maissons-Lafitte and Rue du Débarcadère).

The workshops at Rue de Du Débarcadère have been shown in well known photographs of the Bugatti aeroplane and the motor torpedo boat (see Newsletter 25, pages 16 & 17). Until recently we did not know that there was a drawing office on the top floor. Jean Sibille worked as an apprentice draughtsman there when he was 15 years old in 1939 and he produced a wonderful perspective drawing of the office in 2002. This picture was published in Pegasus which is the newsletter of the Bugatti aircraft Association and we are grateful to the editor, Jaap Horst, for arranging permission for us to reprint it. **See illustration – centre pages.**

There is a great deal to be seen in this drawing showing the team working on

detail design of the Bugatti aeroplane. In the centre we have Ettore in his bowler hat standing just in front of a large scale model of the aeroplane which is hanging from one of the roof's steel trusses. Ettore is in conversation with Count Louis de Monge. The young man at his drawing board on the right of the picture is Jean Sibille himself. From right to left, starting next to him are André Grenet, Lionel Clémenceau and Elie Giraud who is working from behind his drawing board. On the left of the picture is Mr Huret and beyond him Henri-Jacques Glaizot with Rudolf Huryta in the centre foreground.

From Bugatti Trust factory records we know that there were 12 personnel working on the aeroplane at Rue du Débarcadère and that in order of seniority these were: de Monge, Glaizot, Mulot, Valujenitch, Huryta, Clémenceau, Coubasche, Giraud, Grenet, Ascencio, Madame de Romanet (secretary) and Sibille. Their combined salaries in March 1940 amounted to 24,000 francs.

Apart from the aeroplane the other major project to be carried out at the Rue du Débarcadère was the Bugatti Motor Torpedo Boat (see Newsletter 25) and the manager in charge of that project was Monsieur Villatte.

Boudu sauvé des eaux

Hans Matti

This is the title of an old film where that famous Swiss actor, Michel Simon performed the main role. What has this to do with Bugatti, you wonder, well read on and you will find out.

In 1998 we celebrated in Switzerland the centenary of the Swiss automobile club (ACS). Among many other celebrations the ACS organized the 'Grand Prix du Centenaire' in Lugano between 27th and 30th August 1998. This meeting was open to all kinds of historic cars, but many of them were Bugattis. I entered my faithful 35B (4956/211T) and it was one of the better meetings among all those which I have attended for the last 40 years. One of the events was a race on Ascona airfield. On this occasion, someone attending that race said to me *'we have also a Bugatti here in Ascona, however it is sunken down in lago Maggiore and it*

is a target for the local divers of our lifeboat society'. The idea of a Bugatti being hidden under water was amazing enough and I wanted to know more about it. Having been living at the lakeside town of Rolle (lake Geneva) for many years, I am also a member of the lifeboat society, which is an organisation covering the whole of Switzerland. So I called my colleagues of the society at Ascona to learn more about that mystery Bugatti and I was told that some pictures had been taken underwater of the remains. Finally Pasqualino Trotta from the 'Societa Svizzera di Salvataggio, Ascona' (lifeboat society Ascona) sent me 4 pictures, taken during the seventies, showing the visible parts of the car, mainly the wheels only, since most of the car being now buried in the sludge. From these pictures I could confirm that it was indeed a Bugatti, the typical fixation of the rear spring was clearly visible. The car had wire wheels and the rear end of the chassis was straight. Therefore, it had to be a touring Bugatti, certainly not a GP,

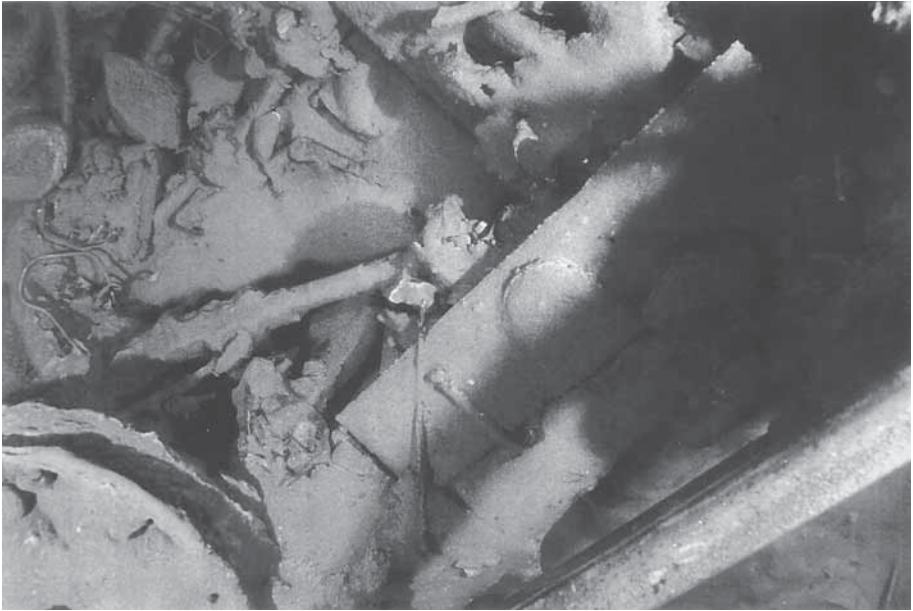

but at that point it was not possible to identify the type, I thought it could be a Type 40.

Nothing else happened until recently. During Locarno carnival festivities on 1st February 2008, Damiano Tamagni, was cowardly attacked by three young hooligans and beaten so heavily that he died, unfortunately, from the injuries which he had suffered. He and his father were members of the Ascona lifeboat and divers society (Centro Sport Subacquei Salvataggio Ascona, CSSS). After the tragedy, his family and friends decided to create a foundation with the aim to prevent juvenile rioting and violence (Fondazione Damiano Tamagni, www.damianotamagni.ch). In order to raise funds for this trust, it was decided to rescue the Bugatti and eventually later to sell it. Jens Boerlin, who runs a firm for underwater work (lavori subacquei), took over the task to rescue the car, which had been resting for more than seventy years at a depth of

53 metres, mostly hidden in the sludge. Jens and his colleagues dived many times down to the car, cleaned it as far as possible and took more underwater pictures, some of which he sent to me. One of these new pictures enabled me to identify the car as a Brescia Modifiée, Type 27. Indeed on this picture (above) one can make out the rear-end of the 4 cylinder engine, with the exhaust manifold and the steering column. The exhaust being on the same side as the steering is only the case for Brescias, all other Bugattis have the exhaust on the opposite side to the steering. Other pictures showed the wooden frame of the body and the axles with four wheel brakes, typical for late Brescias.

On 30th June Jens Boerlin and Renato de Lorenzi took the time to visit my place where I showed them my own Brescia (2651), which is also a Type 27, chassis Type 22 (2.4 metres wheelbase). I showed them especially where to find the chassis number. The next morning,

Jens dived again and he quite easily found the chassis number as being 2461.

A phone call to my friend Norbert Steinhauser revealed the following factory data: Brescia Type 27; engine number 879; chassis Type 22; number 2461 (wheelbase 2.4 metres); twin plug engine; carburettor Solex; rear axle 12 x 45, tyres Michelin; invoiced by Bugatti to the agent Chèvre at Nancy on 22nd April 1925.

Pierre-Yves Laugier took up the trail and came forward with more information. On 11th April already, the car was registered at Nancy with number 8843 N 5 for its first owner, Georges Paiva, 49 Rue des Dominicains at Nancy. However, at this address used to be located the garage atelier of Raymond Apparuyt, who had owned Brescia Bugattis since 1922. He used to race them in local events. He even came 3rd with a Bugatti in the class of 1500cc cars at the second 'Grand Prix du Salon', held at Montlhéry on 16th October 1927. This may well have been 2461.

But how did this car get from Nancy into lago Maggiore? The car bears a little plate giving the following name: Georges Nielly, 48 Rue Nollet, Paris, which must have been one of the subsequent owners, if not the second owner, in France. Local research in Ascona has found at least one witness (Oliviero Barra, now well in his eighties) who has known the car before its disposal into the lake. The story had it, that a young architect, Max Schmuklerski was the owner of the car. However, this proves to be not correct. Since the story of the recovery of the Bugatti has been largely published, the daughter of Max Schmuklerski told us that her father never had owned a Bugatti instead he was the proud owner

of a small French cyclecar made by Bignan.

Meanwhile, another individual has come out, claiming that his father was the owner of the Bugatti at Ascona. This person can prove the fact by showing the French logbook, which has miraculously survived and which is still in his possession. This individual regrets that the car has been recovered and he does not wish to be known, however his identity is known by the author.

The Bugatti was run at Ascona on its French plates and papers, later it was stored in the yard of building contractor Barra, still showing its French plates. The Swiss customs knew of the existence of the Bugatti and they finally insisted on having it imported officially and the corresponding customs fees being paid. This happened between 1936 and 1937 when the car was already quite obsolete, well used and of little value. The customs fee may well have been much more than the actual value of the car. In Switzerland (and probably anywhere else) in case of non-payment of the customs fees, the car has to be destroyed, this was decided upon and the simplest way to get rid of the car was to dip it into the lake. However, it was attached to a chain, in case someone would recover it, but with time the chain rusted through and the car sank to the ground of the lake, where it rested at a depth of 53 metres for the last 73 years.

After the war the local people of Ascona still remembered the Bugatti in the lake, while at the same time the sport of diving got more and more popular. The diving equipment was also greatly improved permitting ever deeper dives. During the sixties the members of the local diving club (Centro Sport Subacquei Ascona) decided to search



for the Bugatti and finally Ugo Pillon located it on 18th August 1967, as registered in their Diving Register. Subsequently it became an appreciated target for the local divers and during the seventies some underwater pictures were taken from the visible remains of the car.

July 12th, 2009 was the great day when 2461 was finally retrieved from the water after all those years. A small delegation of the Bugatti Club Suisse (BCS) assembled at Ascona for the occasion bringing 5 Bugattis along (Types 13 Meier, 22 Matti, 35B Ganter, 37A König and 43 van de Velde). I took my Brescia 2651, which is the same chassis as 2461 to show the two cars side by side. This was a memorable event, the weather was nice and warm and the lake was calm. There was a huge crowd, maybe more than a thousand people, assisting the event. The Bugatti had been transferred by the divers under water within the reach of a big mobile crane. It was attached to the crane and lifted out of the water at 10.30 a.m. speeches were performed by Luigi Pedrazzini (Minister of the Ticinese

Government) and Maurizio Tamagni, the father of Damiano and President of Fondazione Damiano Tamagni in order to explain the aim and sense of the salvation of the Bugatti.

The Bugatti was transferred onto a big trailer, for the crowd to be able to inspect it. Many pictures were taken and videos turned. 2461 was all original and in working order when it was drowned. It has a continuous history and matching numbers. However, its long sojourn in the lake has largely deteriorated it, especially the steel parts. In the lake, the car had been lying on its side, the left side hidden in the sludge, the right side in the open water. The iron and steel parts were quite well preserved in the sludge, but not in the open water, therefore, we have the left side of the car in quite good shape while the right side is largely deteriorated. Other materials like wood, aluminium, brass, rubber, tyres etc. have resisted very well.

Later during the day the Bugatti was removed from the lungo lago (lake front) and brought to the work yard of Boerlin



lavori subacquei at Magadino, where Jens Boerlin and his friends began to clean the car from the remaining sludge. On Monday morning, 13th July, I went to Magadino in order to inspect the Bugatti closer and to check the numbers. It corresponds in all points to the factory data, except for the carburettor, which is the standard Zenith one and not the Solex as stated by the factory. Unfortunately the brass plate is missing, but all the other numbers are there in the usual places. The chassis number 2461 on the right front engine leg, the engine number 879 on the cam box and on the front end of the crankcase, the gearbox number is 964, the differential housing has no number, but the ratio of 12 x 45 is stamped in the usual place. The radiator is Chausson, and it has a second plate reading 'Garantie 244 921' and a third one, probably from a reconditioning firm, reading 'A 3210 26'. On the car were also still the front and rear French Registration plates, unfortunately they

were partly rotted away and the whole number could not be read, however part of the number seems to read RE 1. This registration was issued in Paris between May/June 1930, probably when Georges Nielly got the car from Nancy. This was also the occasion to take many pictures of the car, without being hindered by the crowds.

Of course, this whole event has largely been commented upon on the Internet and thus the whole world was instantly informed. Some Bugatti researchers have soon found out that there is another Bugatti Brescia claiming the number 2461. This car resides today in Japan with Minoru Kawamoto, but it was a Swiss car owned in the sixties by F. Hintermüller in Zürich. This car has engine number 1168 and figures in the 1973 Hugh Conway senior register W3 and in the 1994 Japan register by Shotaro Kobayashi. It always figures as chassis 2461, engine 1168.

However, according to the Molsheim factory data, engine 1168 corresponds to chassis 2761. 2761 was imported into Switzerland on 10th October 1927 and stayed in Switzerland until F. Hintermüller sold it abroad during the seventies. Thus the real 2461 is the car of the lake without the slightest doubt.

Recently the promoters of this project have entrusted Bonhams to sell the car at one of their well known auctions. This will happen at Retromobile in Paris in January 2010. We hope that someone out there will take on the task to preserve this car for posterity; by doing so he will also support a highly important charity (Fondazione Damiano Tamagni). In my opinion it is possible to restore the car, but no more than circa 20% of the original substance can be saved (half of the chassis, most aluminium casings), thus one would end up with a car 20% original and 80% recreation, the unusable parts most certainly getting lost

in time. Therefore, I suggest keeping the car as it is now; just preserving it with the right treatment to prevent further deterioration and put it on static show as such. This is and will always be the yardstick of what an all original, but well used Bugatti Brescia would have been in 1936. Besides, one can build an absolutely accurate replica of the car for use on the road. All the details are still visible and one can recreate an absolutely precise replica which would hopefully not cost much more than the restoration of the original car and it would, most importantly, save the actual car in all its original splendour and glory. This is the one occasion where the construction of a replica does make sense.

The journalist Renato de Lorenzi has covered the whole story with a film which has been shown on Television Ticinese (RSI 1) on 23rd July 2009.

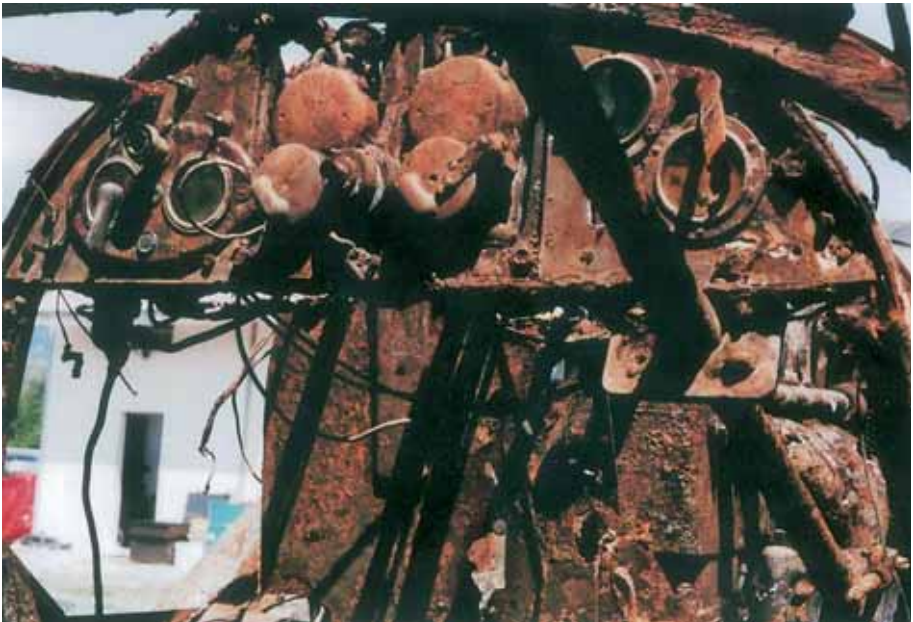



Jean Sibille drawing of the drawing office at 15 Rue du Dé

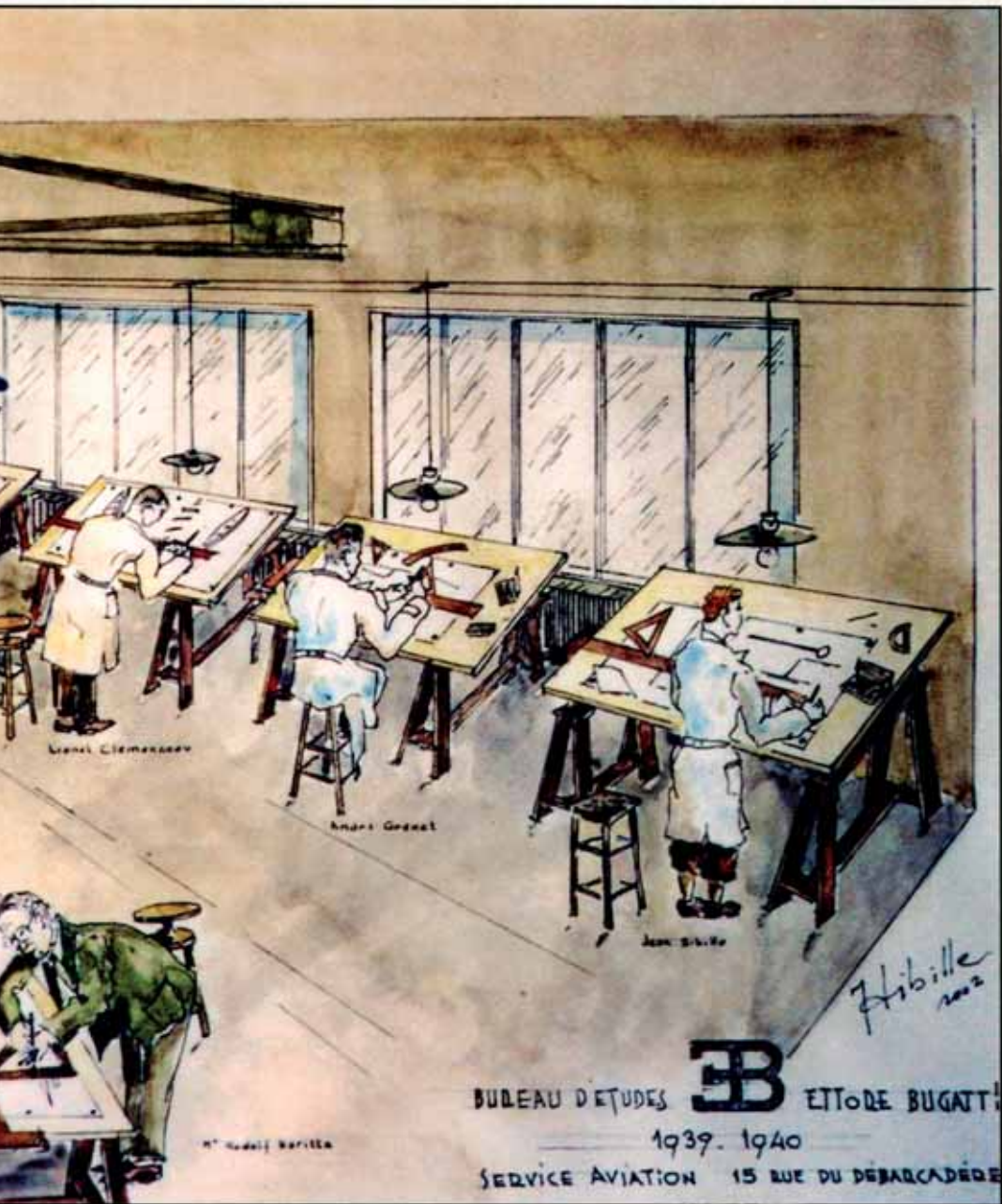

debarcadère. (See pages 5 and 6 – Bugatti's Paris Locations.)

Alexis Kow

Richard Day

Maurice Genevoix of the Académie Française said of the motoring art of Alexis Kow that it was a flying carpet on which to travel through time and connect memories with wondrous dreams. He said that the drawings reconcile the accuracy of working drawings; the rigour of the drawing office with the freedom of a poet.

Alexei Kogeynikov Kow was born into a wealthy Russian family in 1901 and at the age of seven was sent to school in Lausanne. The family lost everything in the Revolution of 1917 and thereafter Alexis became effectively exiled in France. Now, without any backing, he found a job as a junior draughtsman and then he became a graphic artist. For

over four decades he produced posters, advertisements and brochures for many of the French car companies including Panhard, Talbot, Delahaye and Citroen.

In 1936 he was employed by Bugatti in order to produce the new Bugatti catalogue for 1937. The catalogue is an elaborate production having a black card cover with oval cut-out showing a speeding Type 57 with a Bugatti railcar. There is a red celluloid jacket and a red cord tie to the spine.

We could criticise the styling of Alexis Kow's depiction of Bugatti cars. Many of his rendered images seem to be rather stilted and some of the grace of Jean Bugatti's coachwork has been lost. Another niggle: he could never produce a true ellipse. Perhaps Jean was unimpressed. There was no repeat order from Bugatti.



The 1937 Bugatti catalogue cover

LE CHASSIS DONT LA VITESSE
EST INSEPARABLE DE LA SECURITE

3 LIT. 300



TYPE
57

VAINQUEUR

EN 1936

DU GRAND PRIX DE L'AC.F.
GRAND PRIX DE LA MARNE
GRAND PRIX DE DEAUVILLE
GRAND PRIX DU COMMINGES
RECORD DE L'HEURE (218 K. Int^{ed})

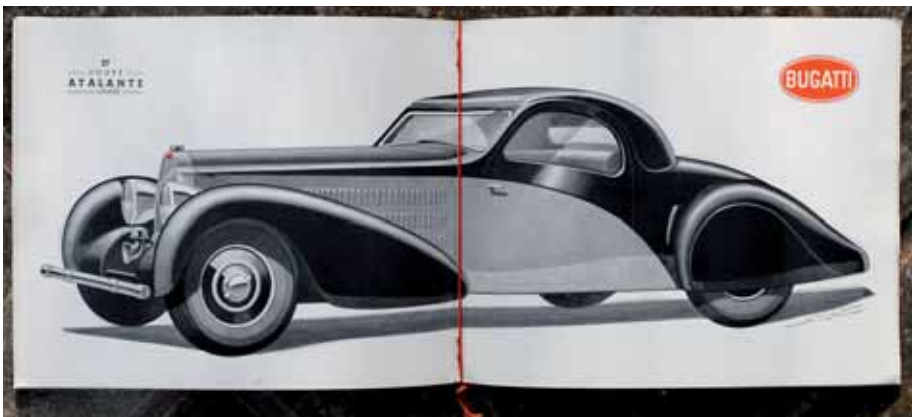

Pages from the 1937 Alexis Kow catalogue

57 . S
CONDUITE INTERIEURE
ATLANTIC
— 2 PORTES — 2 PLACES —
CARROSSERIE PROFILEE
ALLIAGE LEGER
— ASSEMBLAGE RIVETE



CABRIOLET **STELVIO** 4-5 PLACES



ETTORE BUGATTI

MOLSHEIM (Bas-Rhin)

MAGASIN D'EXPOSITION

46 AVENUE MONTAIGNE PARIS

Pages from the 1937 Alexis Kow catalogue

Some Notes on the Type 41 Prototype

(photograph page 1)

Greg Morgan

Anyone reading this newsletter would know that much of what has been written on the subject of Bugatti over many years is based on folklore and myth. Many of these stories emerged so far back in time, that to disprove them requires chipping away at the very bedrock of the Bugatti story.

The Type 41 has suffered more than its fair share of such fairytales and one of the most seemingly watertight ones came about from its debut, when the car was first announced to the English speaking world. In an article for the *Autocar* in June 1926 W F Bradley writes of a “Remarkable Straight Eight Car of nearly Fifteen Litres Engine Capacity” taking shape at Molsheim. He goes on to describe the engine in some detail, with a “bore and stroke of 125 x 150 and a cubic capacity 14726 c.c.” However for the chassis, he simply states: “a wheelbase of slightly more than 15ft”. At this point the car was unfinished and the rather ambiguous description of the chassis suggests that it was at a less advanced stage than the engine.

The following March, Bradley is reporting a road test of the completed car and gives the wheelbase as 15ft 4in.

This car was the prototype for the Bugatti Royale, and it was understandably different from the finalised design of the production cars that evolved from it. For example, to improve braking performance the drum

diameter was increased and, as the drums were integral with the wheels, the change altered the physical appearance of the wheel.

Other differences are less visible and are only spoken of because of the early *Autocar* articles stated below:

Bore and stroke were quoted as 125 x 150 for the prototype. Engine capacity - 14,726cc (sic)

Bore and stroke for the production car was 125 x 130, engine capacity – 12,764cc

Wheelbase of the prototype was quoted as 15ft 4in (4674mm)

Wheelbase of the production car was 4300 mm [374mm (14¾ ins) less]

As is well known, the prototype chassis was destroyed in an accident in the spring of 1931, and all the six remaining cars have the 4300mm wheelbase and 12,764cc engine.

So for the entire history of the Type 41, this already huge car was, once upon a time, supposed to be even bigger. With Bradley’s contemporary reporting such a seemingly reliable point of reference, every book and article written on the subject has expressed these facts as given.

Recently I was studying the factory drawings of the wheels for the Royale prototype and I was comparing the drawing against a perfect side view photograph of the same car and decided to test for myself how long the wheelbase was by scaling from the drawing, using the very simple formula:

$$\frac{\text{Diameter of wheel on drawing (674 mm)}}{\text{Diameter of wheel in photograph}} = \text{scale factor}$$

Scale factor multiplied by wheelbase in photograph = approximate actual wheelbase

I was surprised to discover that the figure came out far shorter than the expected length of 4674mm, but within 20mm of 4300mm. In other words, the photo of the prototype was showing that the wheelbase was about the same as the production cars. Thinking that it may be down to foreshortening via the camera lens, I then tried it out on every side view photo I could find, including the production cars. Every time, the figure was within 50mm of the 4300mm figure.

This seemed conclusive proof that the wheelbase of the prototype was not over a foot longer than the production car, as had always been written, but was actually the same.

On a recent trip to the Bugatti Trust I put my theory to Richard Day, who suggested that we look at the factory drawings and compare measurements. The first thing we found was that the prototype chassis drawing had been amended with a later drawing for the production car, but then when we examined them in detail, we realised that the prototype chassis was actually *shorter* than the production chassis by 80mm!

Presumably the front springs on the prototype were inadequate, and needed to be lengthened by 80mm ahead of the front axle, necessitating the amended drawing, but everything after this point was identical on both drawings.

So if Bradley was wrong on this fundamental point, how well does it

stand up when he reported the prototype as having an extra two litres under the bonnet? There was obviously a need to alter the wheels because the brakes needed to be larger and more powerful, or alter the front springs to improve the ride, but would Bugatti have gone to the considerable trouble of reducing the stroke on a mono block engine, just to make it slightly less massive? There are

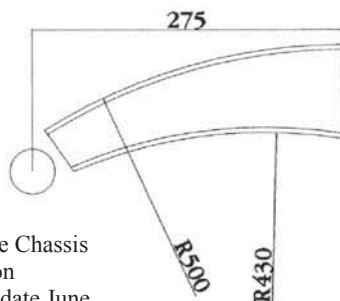

Prototype Chassis
dumb iron
drawing date June
1926

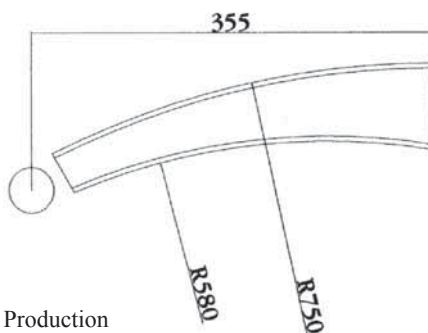

Production
Chassis dumb iron
drawing date
15 December 1930

Illustrations to show the difference between the Prototype and the Production Type 41 chassis frame

2012 Type 41 drawings at the Bugatti Trust. None of them shows a crankshaft of 150mm stroke.

Researching the obscure history of something that was destroyed almost eighty years ago relies entirely on the photographic and printed record. The copies of the factory drawings held at the Bugatti Trust can unlock pieces

of information that have been lost for decades.

Whilst writing this piece, I have just noticed something else. The radiator in the earliest photographs appears to be narrower and more tapered than in the later photos. I feel another trip to the Bugatti Trust is required!

The Bugatti Factory at 100

Hugh Conway

Ettore Bugatti would be amazed. Nearly half a century after the family ceded his factory to Hispano-Suiza several of the early buildings remain and have been beautifully preserved. More than that: he would surely have been impressed by the work going on there.

Messier-Bugatti, as it is now known, is part of an international group employing 52,000 people world-wide. It is a thriving business producing advanced products for the aviation industry, not just France. It is a world leader in the production of aircraft undercarriages, wheels and brakes. If you have flown in a European A320 Airbus it will most likely have had Messier-Bugatti undercarriages. It is the supplier of numerous parts for the latest A380 super jumbo. The factory also houses Messier



The building on the left was Bugatti's first car assembly shop in 1910



The stables (rear) now a store

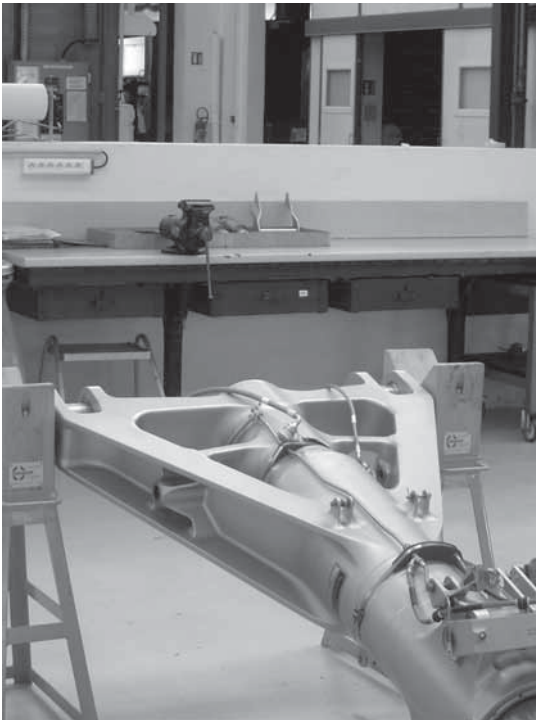

Messier Services – Bugatti vice in background!

Services and the two between them employ about 800 people.

George Messier is one of the founding fathers of the French aviation industry and made a significant contribution to its development. With Ettore Bugatti he shared the same spirit of invention, versatility and demanding standards in his field.

The company is clearly proud of its connection to Bugatti and joined in the celebrations of the centenary in September. Those who were fortunate enough to tour the factory will have noticed a number of Bugatti vices still in use alongside the production of latest undercarriage components; surely a tribute to the quality and longevity of Ettore's products.



Residence now used as training and conference centre

Another Bugatti Myth?

Hugh Conway

The 5 litre type 18 Bugatti “Black Bess” supplied to Roland Garros is so well known that one would think that there could be nothing more to be told about it.

At about the same time of the car’s sale in early 2009 Ian Craighead, Head of Corporate Heritage of the Rolls-Royce Heritage Trust paid a visit to the Trust so it was an opportunity to show him the letter written by Ettore Bugatti to Colonel G.M. Giles claiming to have patented a valve design used by Rolls Royce. The letter is reproduced in the book of the car written by Bill Boddy.¹

A paragraph in the letter (translated) states,

¹ “Black Bess”, The Story of an Edwardian Bugatti by William Boddy published by Aries Press 1993

“It will perhaps interest you to know that the valve control design as used on this car is the one adopted by Messrs. Rolls-Royce for their aeroplane engines, the patent for this device having now expired.”

This comment merited further investigation as there were features about the early 5 litre cars which may have been considered unusual. They had the first of his engines with three overhead valves per cylinder, two inlet and one exhaust, operated by a single overhead camshaft and finger tappets. This design continued through his war time aero engines (except the first 200 HP, engine which had 4 valves per cylinder) and was later adopted for his 4 and 8 cylinder racing and touring models, that is until he changed over to twin overhead camshafts for the touring Type 50 and racing Type 51.

The finger tappets were fitted with rollers so could this possibly be the

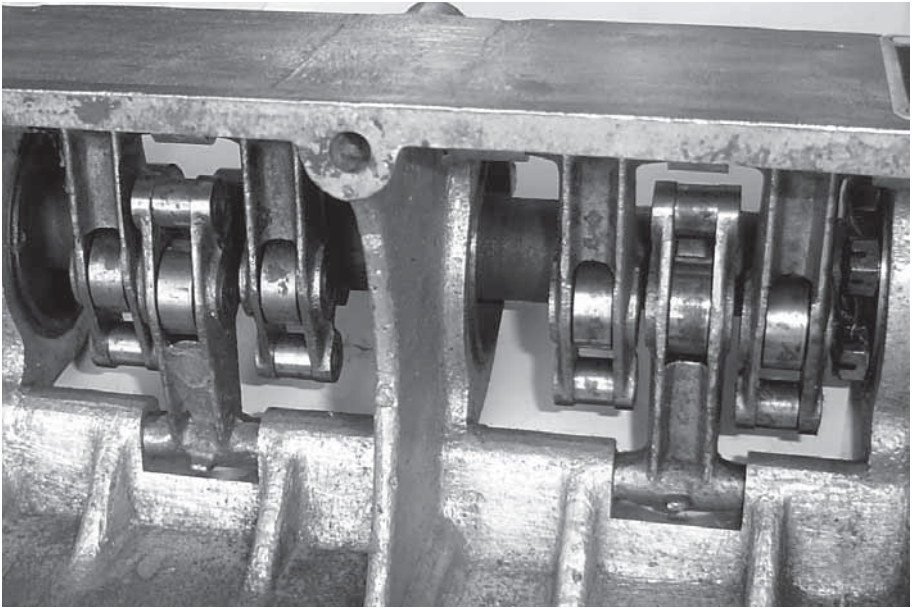

View from below of the Bugatti-King Aero engine cambox

feature Bugatti was referring to? A search of the extensive patent documents seemed to offer no other possibility.

Sometime later Ian Craighead replied to say that the claim had generated a lively debate among his membership as well it might. His comments too seemed conclusive.

He said it was true that Royce's first aero engine had them in, but equally, so had several others before the turn of the 20th Century. He quoted numerous other examples including 1906 40/50 (Silver Ghost). Therefore, the technology certainly was around before the engine.

Whilst one might imagine that EB's claim may have been due to the validity of foreign patents within France as there is no doubt patents taken out in the early years were not as robust as today. However as far as can be established only two have been found specifically

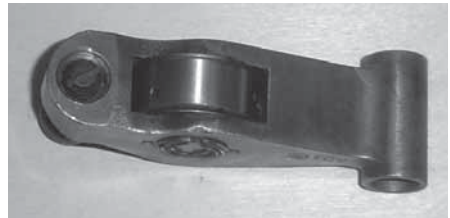

The Type 41 Royale rocker had the same feature

relating to valve operation and each was also registered in England so that is unlikely to have been the reason.²

The conclusion has to be that Ettore was either being imaginative in claiming them as his invention or was there some other feature he had in mind which we have failed to identify?

² GB Patents: Improvements in Valve Distributing Gear for Internal Combustion Engines. GB100266 (May 1916) and GB103115 (May 1917)

If you know someone who may be interested in joining the Bugatti Trust do pass on these details of membership.



Prescott Hill, Gotherington, Cheltenham, Gloucestershire GL52 9RD, UK
Tel +44 (0)1242 677201 • Fax +44(0)1242 674191
E: info@bugatti-trust.co.uk
www.bugatti-trust.co.uk

NEW FORM please read carefully!

APPLICATION/RENEWAL FOR MEMBERSHIP 2010

Please note that as from 2010 membership will begin on 1st January and end on 31st December

I hereby apply to become a member of the Bugatti Trust, formally known as Bugatti Molsheim Limited. I acknowledge that as a member I will be liable to contribute to such a company a sum of not exceeding UKP £1 (One pound sterling) in the event that the company is wound up and cannot meet its liabilities.

Membership: a. Single b. Life

a. Single membership UK & Overseas £35 per year

**As from 1st January 2010 Single Membership will be £35 per year for UK and OVERSEAS
This applies to anyone joining or renewing after 31st October 2009**

b. Single Life Membership £1000 (minimum donation)

**UK tax payers only: Why not GIFT AID your subscription, which will benefit the Bugatti Trust? If you have not done so already do fill in a Gift Aid Form – it need only be filled in once.
Please request a form from the Trust if you require one or download from the website.**

Due to high bank charges the Bugatti Trust does not accept foreign cheques or currency.

*I enclose a cheque/*I wish this payment to be charged to my credit card (*please delete as necessary)

Card Number/...../...../..... Start Date/..... Expiry Date/.....

Issue No..... (if applicable) Security Code: (last 3 digits reverse of card)

Name on Card Signature of card holder

PLEASE COMPLETE THIS SECTION IN BLOCK CAPITALS

Title Full Name

Address

..... Post Code Country

Tel (Home) Tel (Business)

Mobile Fax e:

Applicant's signature Date

Please sign and return the whole form to The Secretary at the above address.

Founder : H G Conway CBE

Bugatti Molsheim Ltd. Reg. Office as above. Company Regn. No. 2180021. Charity Regn. No. 298099

BTMF/2010

Items for sale at the Bugatti Trust

BOOKS

<i>Bugatti – Notice de Conduite et Entretien</i> Chassis Type 40 and Chassis Type 38 1926-27 together with English translation text only	£20 plus post and packing UK £2.00 Europe £3.00 Rest of World £5.00
<i>Grand Prix Bugatti, 3rd Edition by H G Conway</i>	£45 plus post and packing UK £8 Europe £9 Rest of World £18
<i>Bugatti T57S by Bernhard Simon & Julius Kruta</i>	£85 plus post and packing UK £12 Europe £17 Rest of World £28
<i>Full Throttle – Bugatti by Tracy Maurer</i> (Children's book)	£11.00 plus post and packing Postage as for DVDs below
<i>Bugatti – From Milan to Molsheim</i> <i>Uwe Hucke and Julius Kruta</i>	£230.00 - collection from Bugatti Trust only

DVDs

<i>Bugatti DVD by H G Conway – Part 1</i> (Running time 70 minutes) PAL/NTSC format both formats available (please state which you require)	£19.99 plus post and packing UK £2.00 Europe £3.00 Rest of World £5.00
<i>NEW! Bugatti DVD by H G Conway - Part 2</i> (Running time 1 hour 10 minutes) PAL/NTSC please state which you require	£19.99 plus post and packing as above
<i>Raglan avec Elégance</i> Talk given to the Bugatti Trust Members on 18 January 2009	£12.99 plus post and packing as above

A few back issues of the Bugatti Trust Newsletters are still available - at £10 each plus post and packing.

Any of the above can be obtained direct from the Bugatti Trust by telephoning +44 (0)1242 677201 during office hours, or by emailing to info@bugatti-trust.co.uk please also refer to our web site for other information on items for sale:- www.bugatti-trust.co.uk